

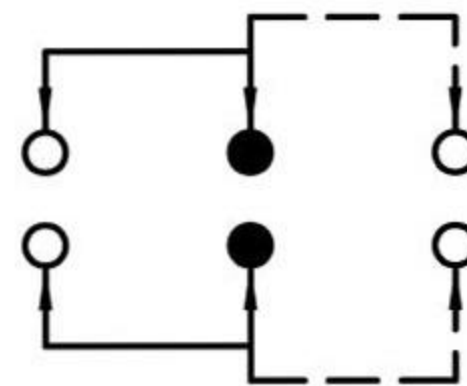

CAD FILE:

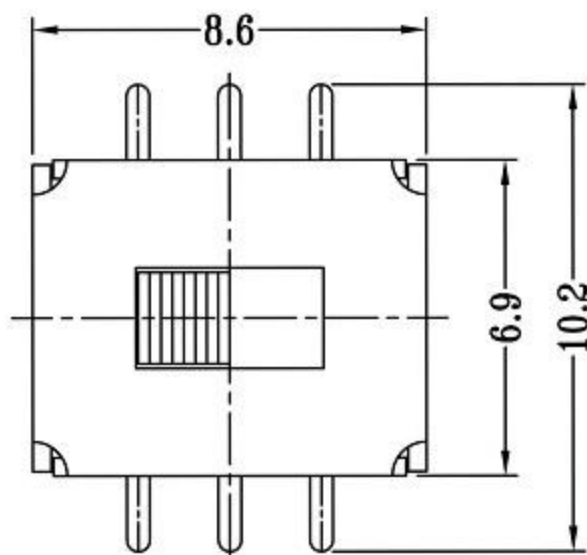
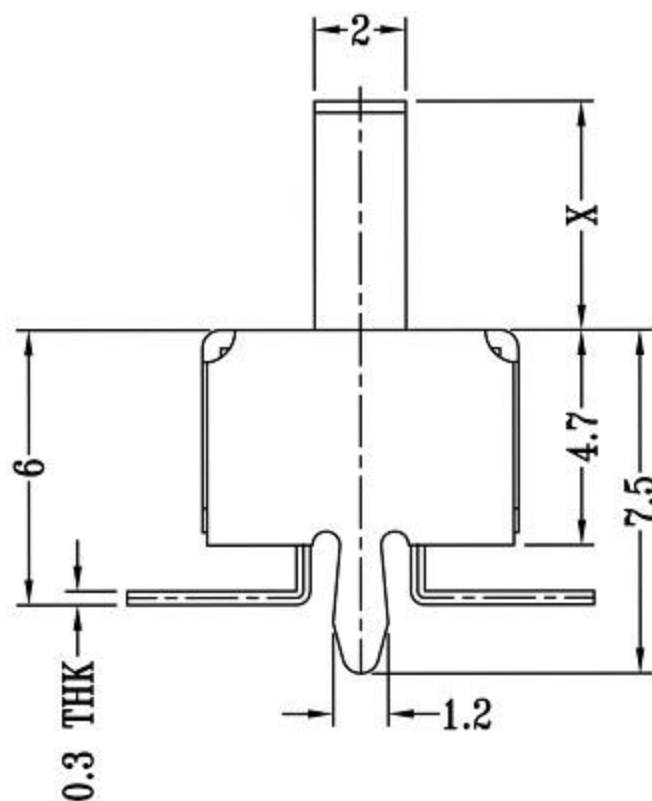
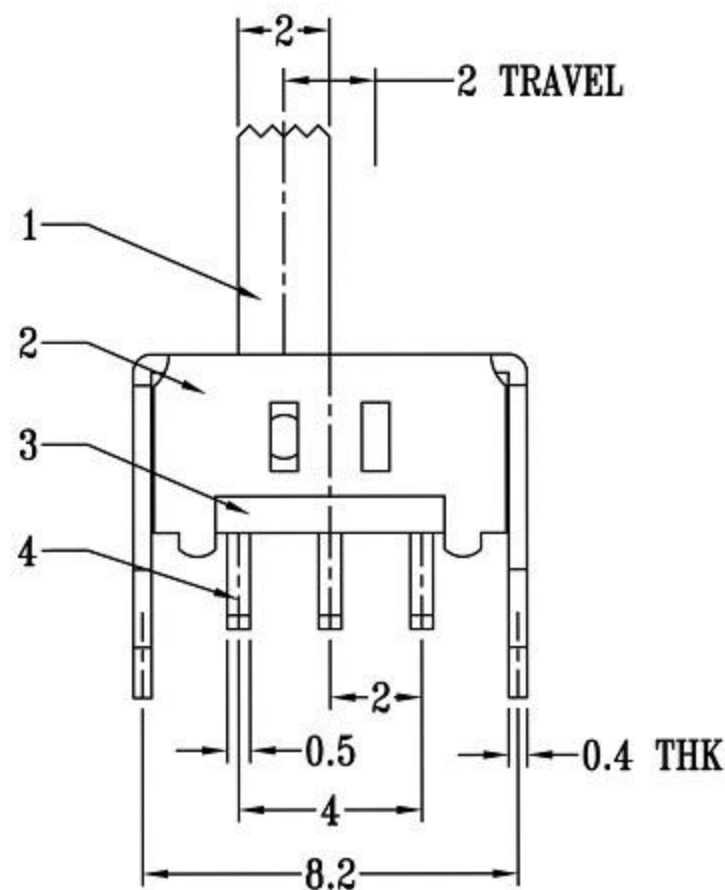

**SCHEMATIC (NON-SHORTING)**

拨动开关立式技术参数:

1. 额定负荷: DC 30V 50V 0.3A 0.5A
2. 接触阻抗:  $\leq 50m\Omega$
3. 绝缘阻抗:  $\geq 100m\Omega$  DC500V
4. 耐焊温度:  $250 \pm 5^\circ$  5s
5. 使用寿命: 10,000 cycles
6. 使用温度:  $-25^\circ\text{C}$  to  $80^\circ\text{C}$
7. 使用湿度:  $\leq 85\%$  RH
8. 操作力: 160gf 256gf 300gf 可定制
9. 手柄长度: 2mm-10mm 可定制

注: "\*"表示关键尺寸(6个)

| NO. | PARTS        | MATERIALS      | Q'TY | FINISH    | TOLERANCE UNLESS SPECIFIED    |       | DESCRIPTIONS OF REVISION |           | APPD.      |  |
|-----|--------------|----------------|------|-----------|-------------------------------|-------|--------------------------|-----------|------------|--|
| 8   |              |                |      |           | WITHIN                        | A     | 2012-10-28               | 初版        |            |  |
| 7   | STEEL BALL   | STEEL          | 1    | NATURAL   | OVER                          | ISSUE | DATE                     |           |            |  |
| 6   | SPRING       | STEEL WIRE     | 1    | NATURAL   | TITLE : VERTICAL SLIDE SWITCH |       |                          |           |            |  |
| 5   | CONTACT CLIP | PBS STRIP      | 2    | Ag PLATED | MODEL:                        |       | UNIT : mm                | DRWG NO.: |            |  |
| 4   | TERMINAL     | BRASS STRIP    | 8    | Ag PLATED |                               |       | SCALE: 3:1               | DWN.      | 2012-10-28 |  |
| 3   | BASE         | PHENOLIC RESIN | 1    | NATURAL   | 东莞市高迪电子有限公司                   |       |                          |           | CHK'D      |  |
| 2   | FRAME        | STEEL STRIP    | 1    | Ni PLATED |                               |       |                          |           | APPD.      |  |
| 1   | KNOB         | POM            | 1    | BLACK     |                               |       |                          |           |            |  |